

ELECTRONICS ENGINEERING

NETWORK THEORY

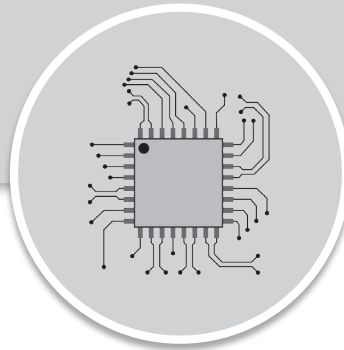

Comprehensive Theory
with Solved Examples and Practice Questions





MADE EASY Publications Pvt. Ltd.

Corporate Office: 44-A/4, Kalu Sarai (Near Hauz Khas Metro Station), New Delhi-110016 | **Ph. :** 9021300500

Email : infomep@madeeasy.in | **Web :** www.madeeasypublications.org

Network Theory

Copyright © by MADE EASY Publications Pvt. Ltd.
All rights are reserved. No part of this publication may be reproduced, stored in or introduced into a retrieval system, or transmitted in any form or by any means (electronic, mechanical, photo-copying, recording or otherwise), without the prior written permission of the above mentioned publisher of this book.

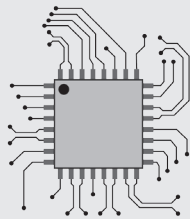

MADE EASY Publications Pvt. Ltd. has taken due care in collecting the data and providing the solutions, before publishing this book. In spite of this, if any inaccuracy or printing error occurs then **MADE EASY Publications Pvt. Ltd.** owes no responsibility. We will be grateful if you could point out any such error. Your suggestions will be appreciated.

EDITIONS

First Edition : 2015
Second Edition : 2016
Third Edition : 2017
Fourth Edition : 2018
Fifth Edition : 2019
Sixth Edition : 2020
Seventh Edition : 2021
Eighth Edition : 2022
Ninth Edition : 2023
Tenth Edition : 2024
Eleventh Edition : 2025
Twelfth Edition : 2026

CONTENTS

Network Theory

CHAPTER 1

Basics Components and Electric Circuits 1-16

1.1	Introduction.....	1
1.2	Charge.....	1
1.3	Current.....	2
1.4	Voltage.....	3
1.5	Power	4
1.6	Energy	6
1.7	Circuit Elements	7
1.8	Sources	9
	<i>Objective Brain Teasers</i>	11

CHAPTER 2

Basic Laws..... 17-48

2.1	Introduction.....	17
2.2	Ohm's Law and Resistance.....	19
2.3	Nodes, Paths, Loops and Branches.....	21
2.4	Concept of Branch Voltage and Node Voltage.....	21
2.5	Kirchhoff's Law.....	22
2.6	Series Resistance and Voltage Division.....	25
2.7	Parallel Resistance and Current Division	25
2.8	Source Transformation.....	26
2.9	Sources in Series or Parallel.....	28
2.10	Wye-Delta Transformations.....	30
2.11	Network Manipulations for Easy Analysis.....	31
	<i>Objective Brain Teasers</i>	35
	<i>Conventional Brain Teasers</i>	48

CHAPTER 3

Basic Nodal and Mesh Analysis 49-69

3.1	Introduction.....	49
-----	-------------------	----

3.2	Nodal Analysis.....	49
3.3	Nodal Analysis with Voltage Source.....	51
3.4	Mesh Analysis.....	53
3.5	Mesh Analysis with Current Sources.....	55
3.6	Comparison Between Nodal Analysis and Mesh Analysis	57
	<i>Objective Brain Teasers</i>	58
	<i>Conventional Brain Teasers</i>	65

CHAPTER 4

Circuit Theorems..... 70-95

4.1	Introduction.....	70
4.2	Linearity and Superposition	70
4.3	Source Transformation.....	72
4.4	Thevenin's Theorem	74
4.5	Norton's Theorem	78
4.6	Maximum Power Transfer	81
	<i>Objective Brain Teasers</i>	84
	<i>Conventional Brain Teasers</i>	89

CHAPTER 5

Capacitors and Inductors 96-112

5.1	Introduction.....	96
5.2	Capacitors.....	96
5.3	Capacitance Combinations	100
5.4	Inductors.....	102
5.5	Voltage, Current and Energy Relationship of an Inductor.....	102
5.6	Inductor Combinations	104
	<i>Objective Brain Teasers</i>	105
	<i>Conventional Brain Teasers</i>	111

CHAPTER 6**First Order RL and RC Circuits 113-147**

6.1	Introduction.....	113
6.2	Definition of the Laplace Transform.....	113
6.3	Circuit Elements in the s-domain.....	117
6.4	Source-Free or Zero-Input Response.....	119
6.5	Step Response of First Order Circuit	126
	<i>Objective Brain Teasers</i>	134
	<i>Conventional Brain Teasers</i>	141

CHAPTER 7**Second Order RLC Circuits.....148-179**

7.1	Introduction.....	148
7.2	Finding Initial and Final Values	149
7.3	The Source-Free Series RLC Circuit.....	150
7.4	Source-Free Parallel RLC Circuit.....	154
7.5	Step By Step Approach of Solving Second Order Circuits.....	156
7.6	Step Response of Series RLC Circuit.....	156
7.7	Step Response of Parallel RLC Circuit	158
7.8	Circuit Analysis in the s-Domain.....	160
	<i>Objective Brain Teasers</i>	166
	<i>Conventional Brain Teasers</i>	170

CHAPTER 8**Sinusoidal Steady-State Analysis 180-223**

8.1	Introduction.....	180
8.2	Sinusoids.....	180
8.3	Phasors	182
8.4	Phasor Relationship for Circuit Elements.....	183
8.5	Impedance and Admittance	185
8.6	Kirchhoff's Laws in the Frequency Domain.....	186
8.7	Impedance Combinations	188
8.8	Circuit Analysis in Phasor Domain	193

8.9	Phasor Diagrams	203
	<i>Objective Brain Teasers</i>	208
	<i>Conventional Brain Teasers</i>	214

CHAPTER 9**AC Power Analysis..... 224-248**

9.1	Introduction.....	224
9.2	Instantaneous Power.....	224
9.3	Average Power.....	225
9.4	Effective or RMS Value.....	227
9.5	Average Value of Periodic Waveform.....	230
9.6	Complex Power and Its Components.....	231
	<i>Objective Brain Teasers</i>	237
	<i>Conventional Brain Teasers</i>	242

CHAPTER 10**Magnetically Coupled Circuits.....249-272**

10.1	Introduction.....	249
10.2	Self Inductance	249
10.3	Mutual Inductance	250
10.4	The Ideal Transformer.....	257
	<i>Objective Brain Teasers</i>	261
	<i>Conventional Brain Teasers</i>	265

CHAPTER 11**Frequency Response & Resonance.....273-299**

11.1	Introduction.....	273
11.2	Transfer Functions	273
11.3	Resonant Circuit	274
	<i>Objective Brain Teasers</i>	291
	<i>Conventional Brain Teasers</i>	295

CHAPTER 12**Two Port Network..... 300-334**

12.1	Introduction.....	300
------	-------------------	-----

12.2	Z-Parameters	300
12.3	Y-parameters	303
12.4	h-parameters or Hybrid Parameters	305
12.5	g-parameters or Inverse Hybrid Parameters	307
12.6	Transmission Parameters (ABCD)	308
12.7	Inverse Transmission Parameters	310
12.8	Inter Relations in Network Parameters	311
12.9	Interconnection of Two-port Networks	311
12.10	Network Components.....	316
12.11	Barletts Bisection Theorem.....	316
12.12	Open Circuited & Short Circuited Impedances	317
	<i>Objective Brain Teasers</i>	318
	<i>Conventional Brain Teasers</i>	324

CHAPTER 13

Network Topology.....335-353

13.1	Introduction.....	335
13.2	Network Graph	335
13.3	Tree and Co-Tree	337
13.4	Incidence Matrix.....	338
13.5	Tie-Set	340
13.6	Cut-Set	341
13.7	Duality.....	343
13.8	Filter	344
	<i>Objective Brain Teasers</i>	349
	<i>Conventional Brain Teasers</i>	351



Basics Components and Electric Circuits

1

1.1 INTRODUCTION

Electric circuit theory and electromagnetic theory are the two fundamental theories upon which all branches of electrical engineering are built. Many branches of electrical engineering such as electric machines, control system, electronics, communication and instrumentation are based on electric circuit theory.

A circuit is an energy or signal/information processor. Each circuit consists of interconnections of "simple" circuit elements, or device. In other words we can say that an electric circuit is an interconnection of electric elements. For example, a device (or circuit element) called a 'source' produces a voltage or a current signal. This signal may serve as a source of energy for the rest of the circuit, or it may represent information. Information in the form of such voltage or current signals is processed by the circuit to produce new signals or new/different information.

1.2 CHARGE

One of the most fundamental concepts in electric circuit analysis is that of charge conservation. We know from basic physics that there are two types of charges : Positive and Negative. For the most part, this text is concerned with circuits in which only electron flow is relevant. We continuously transfer charges between different parts of a circuit, we do nothing to change the total amount of charge. In other words, we neither create nor destroy electrons (or protons) when they are running in the electric circuits. Charge in motion represents a current. The fundamental unit of charge is the Coulomb (C).

The following points should be noted about electric charge :

1. A single electron has a charge of -1.602×10^{-19} C and a single proton has a charge of $+1.602 \times 10^{-19}$ C.
2. Charge is quantized, i.e., the charge on a body will always be an integral multiple of the elementary charge.
3. A constant charge may be represented by either Q or q , but an amount of charge that changes over time must be represented by the lower case letter q .

EXAMPLE : 1.1

How much charge is represented by 4600 electrons?

Solution :

Each electron has -1.602×10^{-19} C.

Hence, 4600 electrons will have, -1.602×10^{-19} C/electron \times 4600 electrons = -7.369×10^{-16} C

1.3 CURRENT

Electric current is the time rate of change of charge, measured in amperes (A). Mathematically, the relationship between current i , charge q , and time t is

$$i(t) = \frac{dq(t)}{dt} \quad \dots(1.1)$$

The net movement of 1 Coulomb (1C) of charge through a cross section of a conductor in 1 second (1s) produces an electric current of 1 ampere (1A).

The charge transferred between time t_0 and t_1 is obtained by integrating both sides of Equation (1.1). We gets

$$q(t) = \int_{t_0}^t i(t) dt \quad \dots(1.2)$$

(as t is variable of integration and the limit of integration and variable should not be same)

EXAMPLE : 1.2

The total charge entering a terminal is given by $q = 5t \sin 4\pi t$ mC. Calculate the current at $t = 0.5$ s.

Solution :

$$i = \frac{dq}{dt} = \frac{d}{dt} (5t \sin 4\pi t) \text{ mC/s} = (5 \sin 4\pi t + 20 \pi t \cos 4\pi t) \text{ mA}$$

at $t = 0.5$,

$$i = 5 \sin 2\pi + 10\pi \cos 2\pi = 0 + 10\pi = 31.42 \text{ mA}$$

EXAMPLE : 1.3

Determine the total charge entering a terminal between $t = 1$ s and $t = 2$ s if the current passing the terminal is $i = (3t^2 - t)$ A.

Solution :

$$Q = \int_{t=1}^2 i dt = \int_1^2 (3t^2 - t) dt = \left(t^3 - \frac{t^2}{2} \right) \Big|_1^2 = (8 - 2) - \left(1 - \frac{1}{2} \right) = 5.5 \text{ C}$$

1.3.1 Reference Direction for Current

The direction of an electric current is by convention, i.e., the direction in which a positive charge would move. Thus, the current in the electric circuit is directed away from the positive terminal and towards the negative terminal of the battery.

Electrons actually move through the wires in the opposite direction of current.

A current can be completely described by a value (which can be positive or negative) and a direction (indicated by arrow).

For example, a current of 10 A may be represented as positively or negatively as shown in below figure.

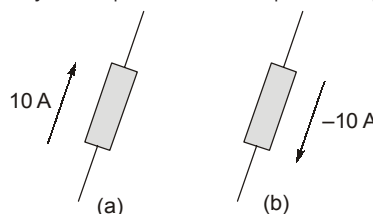

Fig. : Current in a circuit element

1.3.2 Types of Current

There are two kinds of current : Direct Current (DC) and Alternating Current (AC).

- **Direct Current** : A current that is constant in time is termed as Direct Current (DC).
- **Alternating Current** : A current that vary periodically with time is termed as alternating current (AC).

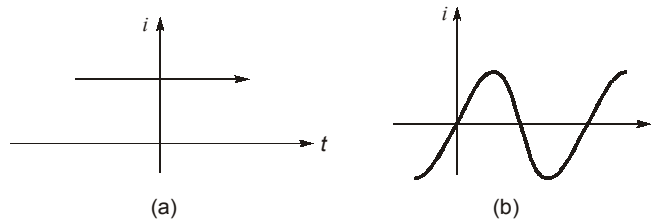

Fig. : (a) Direct current (DC) (b) Sinusoidal current (AC)

1.4 VOLTAGE

To move the electron in a conductor in a particular direction requires some work or energy transfer. This work is performed by an external electromotive force (emf), typically represented by the battery. This emf is also known as *voltage* or *potential difference*. The voltage v_{ab} between two points *a* and *b* in an electric circuit is the energy (or work) needed to move a unit charge from *a* to *b*; mathematically,

$$v_{ab}(t) = \frac{dw}{dq} \quad \dots(1.3)$$

where *w* is energy in Joules (J), *q* is charge in Coulombs (C) and voltage v_{ab} is measured in Volts (V). It is evident that

$$1 \text{ Volt} = 1 \text{ Joule/Coulomb} = 1 \text{ Newton-meter/Coulomb}$$

Thus, **voltage** (or **potential difference**) is the energy required to move a unit charge through an element, measured in Volts (V).

EXAMPLE : 1.4

An energy source forces a constant current of 2A for 10s to flow through a lightbulb. If 2.3 kJ is given off in the form of light and heat energy, calculate the voltage drop across the bulb.

Solution :

The total charge is

$$\begin{aligned} \Delta q &= i\Delta t \\ &= 2 \times 10 = 20 \text{ C} \end{aligned}$$

The voltage drop is

$$v = \frac{\Delta w}{\Delta q} = \frac{2.3 \times 10^3}{20} = 115 \text{ V}$$



REMEMBER

Voltage does not exist at a point by itself; it is always determined with respect to some other point. For this reason, voltage is also called potential difference. We often use the terms interchangeably.

1.4.1 Reference Polarity for Voltage

Voltage is an energy level difference between the points and the polarity of the voltage simply indicates which point has the higher energy level. Voltage polarities are typically indicated on circuit diagrams by “+” and “-” signs as shown in below figure. “+” sign (or point ‘a’) indicate higher energy level compare to “-” sign (or point ‘b’).

It follows logically that general

$$V_{ab} = -V_{ba}$$

$$V_{ab} = V_a - V_b$$

For example, in figure we have two representations of the same voltage. In fig. (a), point *a* is +10 V above point *b*. In fig. (b), point *b* is -10 V above point *a*.

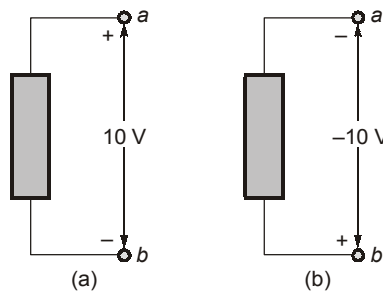

Fig. : Two equivalent representations of the same voltage V_{ab} :
(a) Point ‘a’ is 10V above point ‘b’. (b) Point ‘b’ is -10V above point ‘a’

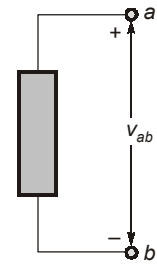

Fig. : Polarity of Voltage V_{ab}



Keep in mind that electric current is always through an element and that electric voltage is always across the element or between two points.

1.4.2 Types of Voltage

There are two kinds of voltages : Direct Current Voltage (DC) and Alternating Current (AC) Voltage.

- DC Voltage : A voltage that is constant in time is termed as DC Voltage.
- AC Voltage : A voltage that vary periodically with time is termed as AC Voltage.

1.5 POWER

If one joule of energy is expended in transferring one Coulomb of charge through the device in one second, then the rate of energy transfer is one watt.

Power,
$$[P(t)] = \frac{dw}{dq} \cdot \frac{dq}{dt} = v(t)i(t) \quad \dots(1.4)$$

We can say that power is simply the product of the voltage across an element and the current through the element.

EXAMPLE : 1.5

Find the power delivered to an element at $t = 3 \text{ ms}$ if the current entering its positive terminal is $i = 5 \cos 60 \pi t \text{ A}$ and the voltage is: (a) $v = 3i$, (b) $v = 3 \frac{di}{dt}$.

Solution :

(a) The voltage is $v = 3i = 15 \cos 60\pi t$; hence, the power is

$$p = vi = 75 \cos^2 60\pi t \text{ W}$$

At $t = 3 \text{ ms}$, $p = 75 \cos^2 (60\pi \times 3 \times 10^{-3}) = 75 \cos^2 0.18\pi = 53.48 \text{ W}$

(b) We find the voltage and the power as

$$v = 3 \frac{di}{dt} = 3 (-60\pi) 5 \sin 60\pi t = -900\pi \sin 60\pi t \text{ V}$$

$$p = vi = -4500\pi \sin 60\pi t \cos 60\pi t \text{ W}$$

At $t = 3 \text{ ms}$, $p = -4500\pi \sin 0.18\pi \cos 0.18\pi \text{ W} = -6.396 \text{ kW}$

1.5.1 Passive Sign Convention for Power Calculation

Current direction and voltage polarity are important in determining the sign of the power. If current enters into the positive (+) terminal then element absorbs the power and if current leaves from the positive (+) terminals then the element delivers the power.

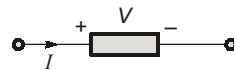

$$P = +VI$$

(a) Power absorbed or power dissipated or power received

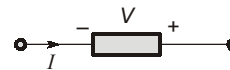

$$P = -VI$$

(b) Power delivered

If the absorbed power P is negative, then the circuit element actually generates power or equivalently, delivers power to the rest of the circuit. The power absorbed by an element and the power supplied by the same element are related by

$$\text{Power absorbed} = -(\text{Power supplied})$$

For example :

(i) The element in both circuit in figure has an absorbing power of +20 W because in both the cases current enters from the positive terminal.

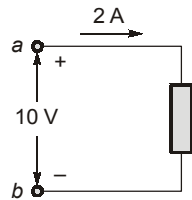

(a)

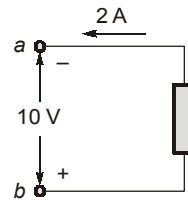

(b)

(ii) The element in both circuit of figure has delivering power of +20 W because in both the cases current enters from negative terminal.

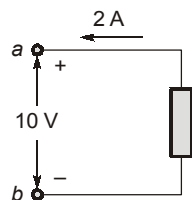

(a)

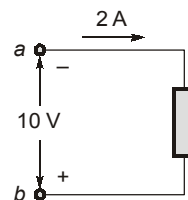

(b)

1.5.2 Law of Conservation of Energy

It states that “Energy can neither be created nor be destroyed, it can only be transformed from one form to another form.”

The algebraic sum of power in circuit at any instant of time must be equal to zero.

$$\Sigma P = 0 \quad \dots(1.5)$$

Thus, sum of the absorbed power is always equal to sum of delivered power in a circuit. So, we can write as

$$\Sigma P_{\text{absorbed}} = \Sigma P_{\text{supplied}} \quad \dots(1.6)$$

EXAMPLE : 1.6

Calculate the power supplied or absorbed by each element in figure.

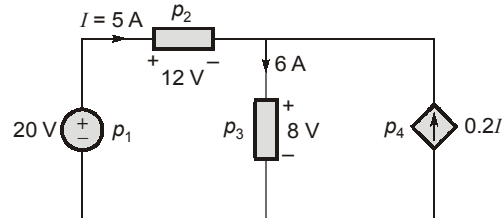
**Solution :**

We apply the sign convention for power shown in figure. For p_1 , the 5 A current is out of the positive terminal (or into the negative terminal); hence,

$$p_1 = 20(-5) = -100 \text{ W absorbed power, i.e., } 100 \text{ W supplied power.}$$

For p_2 and p_3 the current flows into the positive terminal of the element in each case.

$$p_2 = 12(5) = 60 \text{ W Absorbed power}$$

$$p_3 = 8(6) = 48 \text{ W Absorbed power}$$

For p_4 , we should note that the voltage is 8 V (positive at the top), the same as the voltage for p_3 , since both the passive element and the dependent source are connected to the same terminals. (Remember that voltage is always measured across an element in a circuit). Since the current flows out of the positive terminal,

$$p_4 = 8(-0.2I)$$

$$= 8(-0.2 \times 5) = -8 \text{ W absorbed power, i.e., } 8 \text{ W supplied power}$$

We should observe that the 20 V independent voltage source and 0.2I dependent current source are supplying power to the rest of the network, while the passive elements are absorbing power. Also

$$p_1 + p_2 + p_3 + p_4 = -100 + 60 + 48 - 8 = 0$$

The total power supplied equals the total power absorbed.

1.6 ENERGY

It is the ability or the capacity to do the work. The energy over a time interval is found by integrating the power. The energy absorbed or supplied by an element from time 0 to t_1 time is

$$w(t) = \int_0^{t_1} P(t) dt \text{ Joule/Watt-second} \quad \dots(1.7)$$

The electric power utility companies measure energy in watt-hours (Wh), where

$$1 \text{ Wh} = 3600 \text{ J}$$

NOTE : The electric bill that we pay to electric utility companies is paid for electric energy consumed over a certain period of time.

EXAMPLE : 1.7

How much energy does a 100 W electric bulb consume in two hours?

Solution :

$$\begin{aligned} w &= pt = 100 \text{ (W)} \times 2 \text{ (h)} \times 60 \text{ (min/h)} \times 60 \text{ (s/min)} \\ &= 720000 \text{ J} = 720 \text{ kJ} \end{aligned}$$

This is the same as $w = pt = 100 \text{ W} \times 2\text{h} = 200 \text{ Wh}$

1.7 CIRCUIT ELEMENTS

An element is the basic building block of a circuit. By definition, a simple circuit element is the mathematical model of a two-terminal electrical device, and it can be completely characterized by its voltage-current relationship; it cannot be subdivided into other two-terminal devices.

For example,

- If the voltage across the element is linearly proportional to the current through it, then element is called as a **resistor**.
- If the terminal voltage is proportional to *derivative of current* with respect to time, then element is called as a **inductor**.
- If the terminal voltage is proportional to *integral of current* with respect to time, then element is called as a **capacitor**.
- If the terminal voltage is completely independent of current, or the current is completely independent of voltage, then element is called as an **independent source**.
- The element for which either the voltage or current depend upon a current or voltage elsewhere in the circuit; such elements are called as **dependent source**.

1.7.1 Classification of Network Elements

Active and Passive Elements

- Those devices or components which produce energy in the form of voltage or current are called Active Components. E.g., diodes, transistor.
- Active components is also called as Energy Donor. They do not require an external and conditional source to operate in the circuit. They have gain more than 1. So, they can amplify the signal. These circuit components can control the flow of current through the circuit.
- Those devices or components which store or maintain energy in the form of voltage or current are known as Passive Component. E.g., Resistor, Capacitor, Inductor etc. Passive components are also called as Energy Acceptor. Passive components requires an external and conditional source to operate in the circuit. These components are incapable of providing any gain in energy and current.



REMEMBER

- The transistor provide power gain so they are active element, but transformer have same power at input and output they are not active element.
- The active element should be able to provide power/power gain to the circuit for infinite duration of time, that is why the charged capacitor or inductor are not active elements.

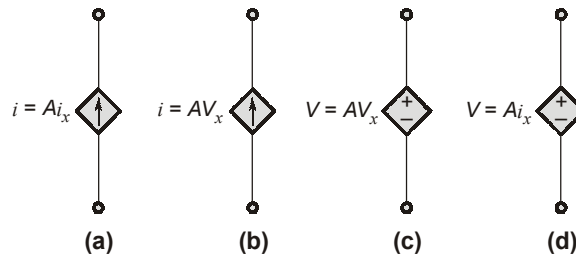

Fig.: The four different types of dependent sources
(a) A current-controlled current source (b) A voltage-controlled current source
(c) A voltage-controlled voltage source (d) A current-controlled voltage source



- A different symbol, in the shape of a diamond, is used to represent dependent sources.
- Dependent sources are very useful in describing certain types of electronic circuits.
- A dependent source may absorb or supply power.



OBJECTIVE BRAIN TEASERS

Q.1 In the figure shown below, when 12 coulombs of charge passes through the element from A to B, the energy absorbed by the element is 60 J. The voltage V across the element is ____.

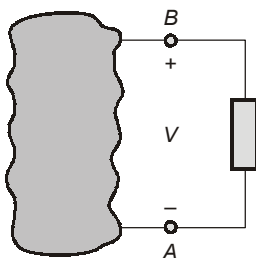

- (a) 5 V
- (b) -5 V
- (c) 10 V
- (d) -10 V

Q.2 In the circuit shown in figure, voltage V_0 is ____ Volts.

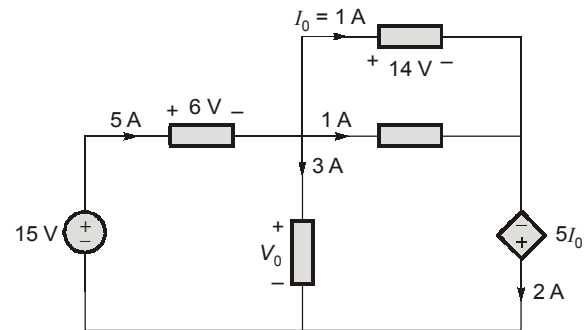

Q.3 For the circuit element shown in figure voltage and current are given as

$$v(t) = 200e^{-50t} \sin 150t \text{ V and}$$

$$i(t) = 10e^{-50t} \sin 150t \text{ A}$$

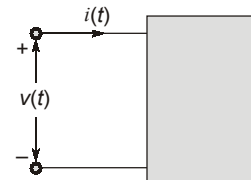

The power absorbed by the element at $t = 20 \text{ ms}$ (in watts) is ____.

Q.4 If $q = (10 - 10e^{-2t}) \text{ mC}$, the current at $t = 0.5 \text{ s}$ is ____ A.

- Q5** In an electron beam in a TV picture tube carries 10^{13} electrons/second and is passing through plates maintained at a potential difference of 30 kV, the power in the beam is _____ mW.
- Q6** Which of the following amount of electrons is equivalent to -3.941 C of charge?
 (a) 1.628×10^{20} (b) 1.24×10^{18}
 (c) 6.482×10^{17} (d) 2.46×10^{19}
- Q7** A circuit consisting of four circuit elements is shown in the figure below. The voltage drops and polarity are indicated in the figure.

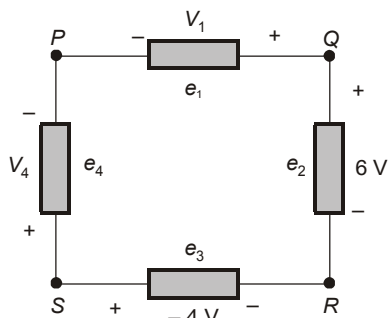

It is given that $V_{PQ} = 8$ V, then what are the values of V_1 and V_{QR} ?

- (a) 8 V, 6 V (b) -8 V, 6 V
 (c) -8 V, -6 V (d) 8 V, -6 V
- Q8** Match List-I (V, I) with List-II (Power absorbed or supplied) for the element shown in figure and choose the correct answer using the codes given below the list.

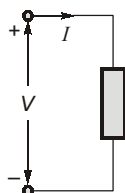

List-I

- A. $V = 5$ V, $I = 3$ A
 B. $V = 5$ V, $I = -3$ A
 C. $V = -8$ V, $I = 2$ A
 D. $V = -8$ V, $I = -2$ A

List-II

1. 15 W, supplied
 2. 16 W, absorbed
 3. 15 W, absorbed
 4. 16 W, supplied

Codes:

- | | A | B | C | D |
|-----|---|---|---|---|
| (a) | 1 | 3 | 2 | 4 |
| (b) | 1 | 3 | 4 | 2 |
| (c) | 3 | 1 | 4 | 2 |
| (d) | 3 | 1 | 2 | 4 |

- Q9** The current through and voltage across the element shown in Figure are given as $v(t) = 4 \cos 3t$ V, $i(t) = 5 \sin 3t$ A.

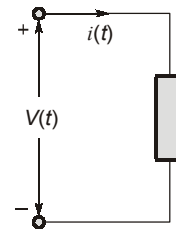

Consider the following statements:

- The maximum value of power absorbed is 10 W.
 - At $t = 0.5$ sec, element absorbs power.
 - At $t = 1$ sec, element delivers power.
- Which of the above statements are true?
 (a) 1 and 3 (b) 2 and 3
 (c) 1 and 2 (d) 1, 2 and 3

- Q10** In the circuit shown below, if dependent source supplies 16 W of power, then the 24 V source

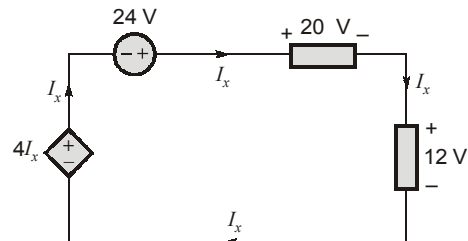

- (a) Supplies 48 W of power
 (b) Absorbs 48 W of power
 (c) Supplies 96 W of power
 (d) Absorbs 64 W of power

- Q11** Let P_i denotes the power absorbed by element e_i in the following circuit. If $P_1 = -210$ W, $P_2 = 45$ W, $P_4 = 50$ W and $P_5 = 20$ W then element e_3

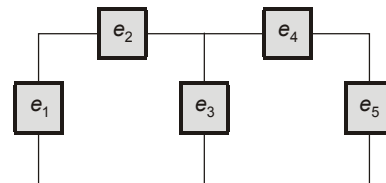

- (a) receives 325 W (b) delivers 95 W
 (c) receives 95 W (d) delivers 325 W

Common Data Questions (13 to 14):

In the electric circuit shown in Figure, voltage V_0 and current I_0 are related as follows

$$V_0 = \begin{cases} 25 - I_0^2, & 0 \leq I_0 \leq 5 \\ 0, & I_0 \geq 5 \end{cases}$$

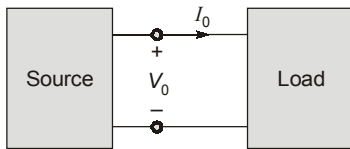

- Q.12** The power absorbed by the load when $I_0 = 3$ A and $I_0 = 4$ A are respectively
 (a) 16 W, 9 W (b) 64 W, 27 W
 (c) 48 W, 36 W (d) 66 W, 84 W
- Q.13** The value of current I_0 , such that power absorbed by load is maximum, will be
 (a) 2.88 A (b) 5 A
 (c) 1 A (d) 1.69 A
- Q.14** In the circuit shown below, which of the following sources are being charged?

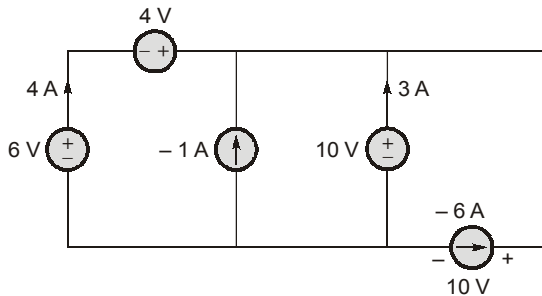

- (a) 6 V, 4 V and 10 V source
 (b) -1 A and -6 A source
 (c) 6 V and -1 V source
 (d) 4 V and 10 V source
- Q.15** The voltage source V_s in the figure
-
- (a) supplies 48 W (b) absorbs 216 W
 (c) absorbs 48 W (d) supplies 216 W
- Q.16** The current in an ideal conductor is plotted in the figure below. How much charge is transferred in the interval $0 < t < 6$ sec (in C)?

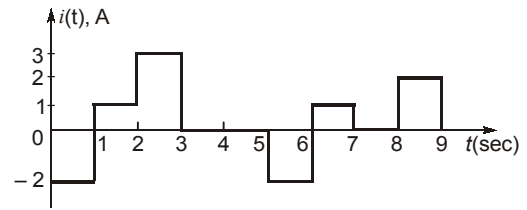

- Q.17** An automobile battery is charged with a constant current of 4 A. The terminal voltage of the battery is $v(t) = 10 + 2t$ V, where t is in hours. The amount of energy (in kJ) is delivered to the battery during 3 hours is _____.

ANSWERS KEY

1. (a) 2. (9) 3. (5.39) 4. (7.358)
 5. (48.06) 6. (d) 7. (b)
 8. (c) 9. (d) 10. (a) 11. (c) 12. (c)
 13. (a) 14. (b) 15. (a) 16. (Sol)
 17. (0.5616)

HINTS & EXPLANATIONS

1. (a)

Charge flow, $Q = 12$ C
 Energy absorbed,
 $E = 60$ J

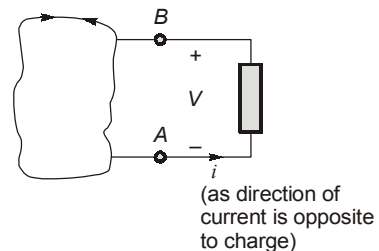

Voltage, $V = \frac{E}{Q} \Rightarrow \frac{60}{12} = 5$ V

2. (9)

$V_1 = 14$ V
 (as connected in parallel across 14 V)

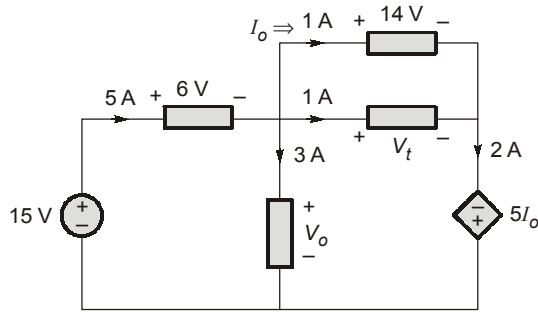

From conservation of energy
 $15 \times 5 + 5I_o \times 2 = 5 \times 6 + 3V_o + 14 \times 1 + V_t \times 1$
 as $I_o = 1 \text{ A}$
 $\Rightarrow 75 + 10I_o = 30 + 14 + 14 + 3V_o$
 $\Rightarrow 85 - 30 - 28 = 3V_o$
 $\Rightarrow V_o = 9 \text{ V}$

3. (5.39)

Given : $V(t) = 200e^{-50t} \sin(150t) \text{ V}$
 $i(t) = 10e^{-50t} \sin(150t) \text{ V}$
 Time, $t = 20 \text{ ms}$

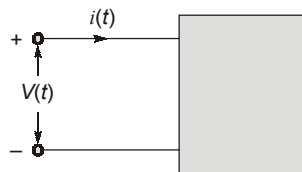

Power absorbed,
 $P = V(t)i(t)$
 $\Rightarrow P = (200e^{-50t} \sin 150t)(10e^{-50t} \sin 150t)$
 $\Rightarrow P = 2000e^{-100t} \sin^2 150t$
 $\Rightarrow P|_{t=20 \times 10^{-3}} = 2000e^{-100 \times 20 \times 10^{-3}} \times \sin^2(150 \times 20 \times 10^{-3})$
 $\Rightarrow P|_{t=20 \text{ ms}} = 5.39 \text{ W}$

4. (7.358)

$q = (10 - 10e^{-2t}) \text{ mC}$
 Time, $t = 0.5 \text{ s}$
 Current, $i = \frac{dq}{dt}$
 $\Rightarrow i|_{t=0.5} = \left. \frac{dq}{dt} \right|_{t=0.5} = \left. \frac{d}{dt}(10 - 10e^{-2t}) \right|_{t=0.5} \text{ mA}$
 $\Rightarrow i|_{t=0.5} = 20e^{-2t}|_{t=0.5} \text{ mA} = 20e^{-1} \text{ mA}$
 $\Rightarrow i|_{t=0.5} = 7.358 \text{ mA}$

5. (48.06)

Given :
 Charge flow per second, $q = 10^{13} \text{ electrons/s}$
 Potential difference, $V = 30 \text{ kV}$
 Current in ampere,
 $I = qe \text{ A} = 10^{13} \times 1.602 \times 10^{-19} \text{ A}$
 $\Rightarrow I = 1.602 \times 10^{-6} \text{ A} = 1.602 \mu\text{A}$
 Power in the beam,
 $P = VI$
 $\Rightarrow P = 30 \times 10^3 \times 1.602 \times 10^{-6} = 48.06 \text{ mW}$

6. (d)

Charge, $Q = -3.941 \text{ C}$
 Number of electrons,
 $n = \frac{|Q|}{e}$
 where e is electronic charge.
 $\Rightarrow n = \frac{3.941}{1.602 \times 10^{-19}} = 2.46 \times 10^{19} \text{ electrons}$

7. (b)

From conservation of energy :

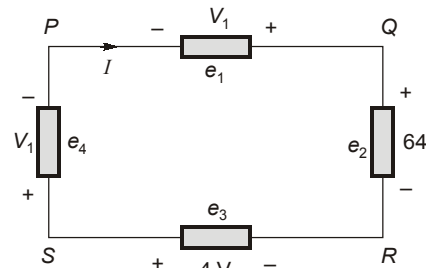

$V_1 I + e_3 I = e_2 I + e_4 I$
 (considering I as shown in figure)
 $\Rightarrow V_1 + e_3 = e_2 + e_4$
 $\Rightarrow V_1 - 4 = 6 + e_4$
 $\Rightarrow V_1 - e_4 = 10 \text{ V}$ and $e_2 = V_{QR}$
 $V_{QR} = 6 \text{ V}$
 $V_{PQ} = 8 \text{ V} = -V_1 \Rightarrow V_1 = -8 \text{ V}$

8. (c)

